

Vision is
our mission®

Camera PTZ Alu
Article no. 0506953
Camera PTZ Alu RS485
Article no. 0516952
2020 • DS0961343 EN A 02

Product Data



Dimensions

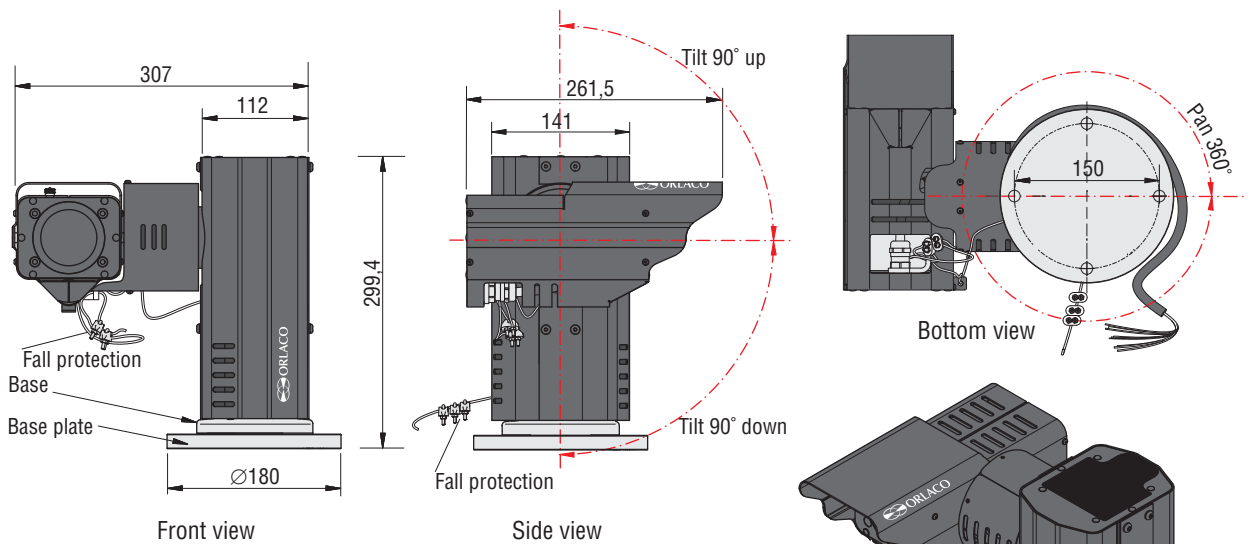

Units in mm

Cable length 5m
3,5m available for installation
Cable Base 9B-1CD-11W
Art. no. 1221300

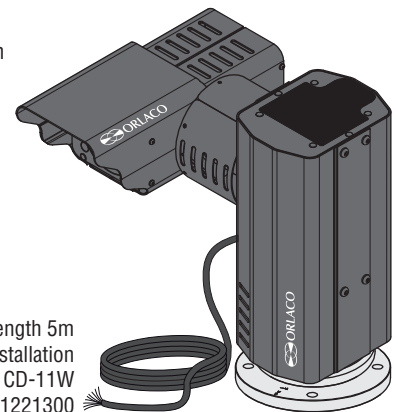

TECHNICAL DATA

Camera PTZ Alu Camera PTZ Alu RS485

Article numbers	Description 0506953 Camera PTZ Alu RS232 0516952 Camera PTZ Alu RS485
	General Pan Tilt unit including zoom camera. The PTZ unit functions via two industrial stepping motors. These stepping motors are controlled by the integrated micro-controller and input commands RS232 or RS485 Visca-, Pelco-D protocol.
	Zoom camera 1/3" CMOS sensor. >700 TV lines (PAL/NTSC). 30x optical, 32x digital zoom. f = 5.1 mm to 51 mm, F1.6 (WIDE) to F1.8 (TELE). High zoom ratio up to 53x when used in PAL/NTSC mode (1.9x digital zoom will not influence image quality. Sensor itself is ± 4x the number of pixels needed to create PAL/NTSC output).
Image sensor	
Hor. Resolution	
Lens	
Angle of view (H)	58.9° (wide) 2,11° (tele).
Minimum illumination	0.5 lux (1/30sec).
	Pan & Tilt Total 360°, 180° left, 180° right. Total 180°, 90° up, 90° down from horizontal. 1°. 12,5°/sec. 128 presets Visca and 255 presets Pelco-D. The PTZ camera can be controlled by means of the Monitor 7" RLED Serial; article no. 0208232 or the Monitor 12" Serial; article no. 0207910.
Pan angle	
Tilt angle	
Backlash PTZ	
Pan & Tilt speed	
Presets	
Controls	
	General Anodised aluminium housing corrosion proof according IEC 60068-2-52 salt mist, cyclic. 1,4 Bar overpressure filled with dry nitrogen, long term stability 0,1%/year. 6,8 kg, including 5m. cable. Length 5m, 3,5m available for installation, Cable Base 9B-1CD-11W, Art. no. 1221300. IP68 according to IEC 60529, Dust tight and protected against the effects of immersion in water up to 10m for 30 minutes and IP69K according to DIN 40050-9, camera can withstand a high pressure cleaning with water: 14-16L/min 80°C and 100 Bars flow. -40°C to +85°C. Puls width modulated thermostatically heating integrated. 18...30V/DC or alternatively 100...240V/AC via SmartBoard. Pan & Tilt; Heating on; 12W, heating off; 8,4W (Automatic heating). Communication via serial interface; Visca-, Pelco-D protocol (RS232 or RS485) 9,6 Kbps, 8 bit, 1 stop bit, no parity. Steel cable fall protection. See installation manual IM0973143.
Housing	
Weight	
Cable	
Ingress protection	
Operating temperature	
Power input	
Power consumption	
Communication	
Included	
Installation	
Green Passport	All materials are compliant to Green Passport requirements according IMO resolution MEPC.197(62) as adopted on 15 July 2011 (Maritime sector:International Maritime Organization concerning the functions of the Marine Environment Protection Committee).

Electrical connections

Cable Base, Art no 1221300

	RS232	RS485		
1 = Coax core	Video	Video		
2 = Coax shielding	Video GND	Video GND		
3 = Red	Camera power	Camera power		
4 = Black	Camera 0V	Camera 0V		
5 = Red/White	Pan/Tilt power	Pan/Tilt power	1 = Red/blue	N.C.
6 = Black/White	Pan/Tilt 0V	Pan/Tilt 0V	2 = Black/blue	N.C.
7 = Green	Serial 1 RS-232 TX	B (inv)	3 = Blue	N.C.
8 = Grey	Serial 2 RS-232 RX	A (non-inv)	4 = Brown	N.C.
9 = Black/Gray	Serial 0V		5 = Shielding	N.C.

Cut off at wire entry
(In Junction box)

All data subject to change without notice. All dimensions are for commercial purpose only.
The camera/display systems from Orlaco comply with the latest CE, ADR, EMC and mirror-directive regulations, where applicable.
All products are manufactured in accordance with the ISO 9001 quality management system, IATF 16949 quality automotive, ISO 14001 environmental management systems and all Ex products with the IECEx scheme and ATEX directives, where applicable.

